

Rafał BERNAT, Bartłomiej LOREK\*, Mariusz KOSOBUDZKI

## **ANALYSIS OF THE EFFECTIVENESS OF CHANGES INTRODUCED TO THE SUSPENSION SYSTEM OF THE SCORPIO 7 MARTIAN ROVER**

**Key words:** *Martian rover, off-road vehicle, suspension, Scorpio, University Rover Challenge*

The paper describes an innovative solution for the suspension system of the Scorpio 7 Martian rover, developed based on the previous generation of the vehicle – Scorpio X. The machine was intended to participate in Martian rover competitions from the Rover Challenge series. The document presents an analysis of the parameters characterising the discussed suspension system, with heavy emphasis on the mass of the platform, deflection under working conditions, amount of space required and angular positions of paramount components. Those characteristics are compared to values describing the systems of Scorpio X.

### 1. INTRODUCTION

In recent years interest in space exploration has been very high. The largest space agency, NASA, has presented its plans to prepare for the Artemis program, a manned mission to the Moon in 2024, and to send another unmanned mission to Mars. Currently, Mars is being studied by 8 separate scientific missions from all over the world. However, technologies sent to distant planets are first developed and tested on Earth. Inspiration for these technologies is sought by organising competitions such as the Rover Challenge series. [1] These competitions are formalised, meaning they are conducted according to established rules and regulations, and the selection of teams for the competitions is preceded by a preliminary stage. Student-built Mars rovers taking part in the competition are an important source of ideas for all space agencies, including NASA. For students, they present opportunities to compete with teams from all over the world, improve their cognitive and technological knowledge, and develop their own ideas and technologies [2]. An example of a Mars rover developed by students from Monash University in Melbourne is shown in Figure 1.

---

\* Wrocław University of Science and Technology, Faculty of Mechanical Engineering, Department of Fundamentals of Machine Design and Mechatronic Systems, Poland



Fig. 1. Rover built by students from Monash University in Australia, presented at the University Rover Challenge 2019

Scorpio 7, a rover designed by students affiliated with the Student Scientific Association OFF-ROAD and operating at the Department of Off-Road Vehicle Engineering of the Faculty of Mechanical Engineering of the Wrocław University of Science and Technologies, meets the requirements set in the regulations of the Rover Challenge competitions. Due to the simulated Martian or lunar conditions during the competitions, all vehicles must be of the off-road class. The basic regulatory requirements for rovers relate to their dimensions: the vehicle must fit in a cube with an edge of 1200 mm and weigh no more than 50 kg [3]. In addition, vehicles are required to have the ability to drive autonomously. [4]. A photo of the Scorpio 7 rover, participating in the competition, and its model, made in the SolidWorks environment, are presented in Figure 2.



Fig. 2. The Scorpio 7 rover at the URC 2022 competition (left) and its 3D model (right)

Participation in the competitions, analysis of the achieved results and rivalry with other teams are the most important sources of data that allow for the continuous development of owned technologies.

## 2. CONSTRUCTION OF THE SCORPIO X SUSPENSION SYSTEM

The suspension of the Martian rover Scorpio X was constructed based on the rocker-boogie suspension concept, which is used by NASA in the construction of such rovers as Curiosity and Perseverance [5]. A conceptual diagram of this type of suspension is visible in Figure 3. In order to reduce weight and simplify the design, the number of wheels used in the bogie, typically four, was reduced to just two.

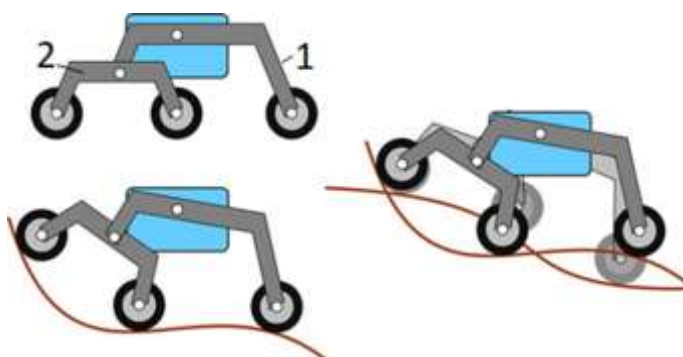

Fig. 3. Diagram of the rocker - boogie suspension system; 1 - rocker, 2 – boogie

The rockers on both sides of the Scorpio X rover were connected through a differential mechanism. The mechanism consisted of a single aluminium beam, supported by bearings in the middle of its length. It was connected to the rockers through a system of pushrods and levers. This solution performed well in fulfilling its tasks but was heavy and required placement in a specially designed cage, taking up a significant amount of valuable space. Additionally, the beam moved in a horizontal plane, which was not favourable due to possible collisions with the vehicle frame and allowed for increased rocker movement. In order to eliminate these drawbacks, it was decided to improve the suspension system parameters in the new generation of the rover, particularly to reduce the total weight and the amount of space occupied by the system during full range of motion. During the design phase, limitations resulting from manufacturing and assembly had to be taken into consideration. Loads acting on individual elements of the new suspension system should not cause plastic deformation, and the entire system should be optimised in terms of mass, volume, and placement. [6]

### 3.CHANGES INTRODUCED TO THE SCORPIO 7 SUSPENSION SYSTEM

In the Scorpio 7 rover, similarly to Scorpio X, the differential mechanism is attached to the rockers through a pushrod supported by ball joints. The mechanism is mounted on the rear wall of the vehicle's body, and its movement takes place in a plane perpendicular to the floor. The construction of the new system is presented in Figure 4. Intermediary elements, such as sway bars or additional levers are not necessary in the Scorpio 7 suspension [7].

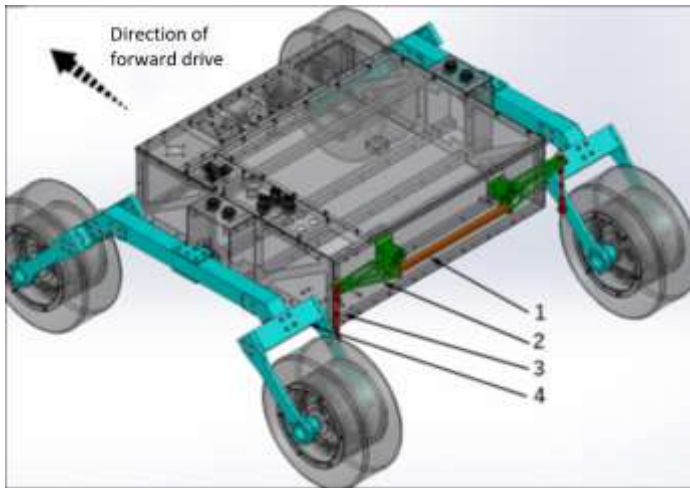

Fig. 4. Scorpio 7 suspension system diagram; 1 (orange) - beam, 2 (green) - triangular beams, 3 (red) – pushrod, 4 (blue) – rocker. The arrow shows the direction of forward drive.

Due to the vertical orientation of the mechanism, great freedom in shaping particular dimensions and individual suspension parts was achieved, which allowed for design so as to minimise forces transmitted from the suspension. The new mounting method induced a change in the pushrod mounting location in relation to the rocker. In Scorpio X, this element was mounted closely to the rocker's axis of rotation. Since pushrod is responsible for transmitting rotational moments from the rocker to the differential beam, its minute distance from the axis of rotation resulted in large forces transmitted by this element. In Scorpio 7, due to the placement of the differential beam on the rear of the vehicle, it was necessary to move the pushrod back, up to the rocker's end. This significantly increased the lever arm and reduced the forces acting on the pushrod.

In order to more evenly distribute forces acting on the frame at the mounting location, it was decided to divide the differential beam, which was a single element in Scorpio X, into a mechanism consisting of five separate beams. Four beams with

a shape derived from a triangle (further referred to as "triangular beams") - two on each side of the vehicle - as well as a square cross-section beam were used. Schematic showing the construction of the mechanism can be seen in Figure 5.

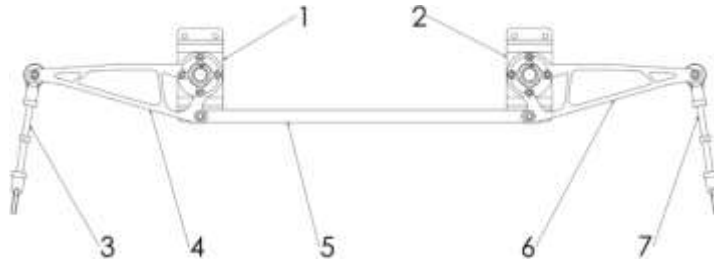

Fig. 5. Diagram showing differential beam mechanism with pushrods; 1 - left mechanism mount, 2 - right mechanism mount, 3 - left pushrod, 4 - left triangular beams, 5 - beam, 6 - right triangular beams, 7 - right pushrod

The triangular beam, shown in Figure 6, was made by laser cutting from 6060 aluminium sheet with a thickness of 4 mm. Dimensions significant for the kinematics of the suspension are arm lengths of 160 mm and 40 mm, located at the vertices of the right triangle, which is shown in Figure 6. The beam connecting the left and right sides of the mechanism is made from the same material as the triangular beams. It is a rectangular pipe with dimensions of 12x12x1 mm and a length of 340 mm.

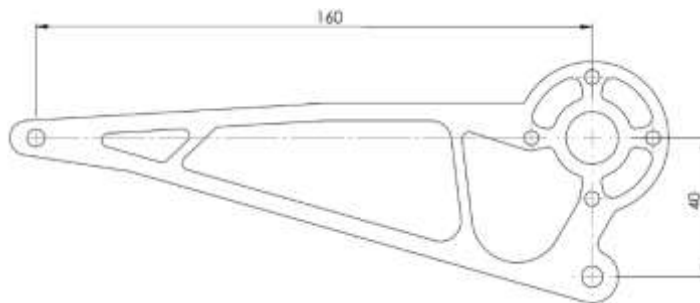

Fig. 6. Drawing showing triangular beam's relevant dimensions

The use of two triangular beams on each side of the mechanism (Fig. 4) is redundant in terms of kinematics but brings benefits related to the assembly of pushrods.

#### 4. ANALYSIS OF LOADS IN THE SUSPENSION SYSTEM

Similarly to its predecessor, the differential mechanism in Scorpio 7 is subjected to deformations due to the forces generated by crossing uneven terrain. The triangular beam shape was designed to have the lowest possible mass while maintaining high bending rigidity. Optimisation of the shape was carried out using results from the FEM analysis [8] performed in SolidWorks. The simulation was intended to show the magnitude of deformations occurring during loading. The mesh was built using the TETRA 10 finite element and a maximum edge length of 1 mm. Loads were assigned based on the results from the multibody dynamics simulation (MDS) [9] performed in MSC Adams [10] for the full range of suspension motion. The maximum element stress results were used to calculate the deformations. Additionally, the following boundary conditions were applied:

- Fixed displacement at the pivot (bearing) location
- Force, with a magnitude of 6 N along the X axis, 23,5 N along the Y axis and -1,5 N along the Z axis, was applied to the pushrod mounting location
- Force, with a magnitude of 78,5 N along the X axis, -26,5 N along the Y axis and -1 N along the Z axis, was applied to the differential beam mounting location



Fig. 7. Displacement map of the loaded triangular beam

The results of the calculations are shown in Figure 7. The largest deformation of the beam (as a result of bending) occurs near the point of attachment to the pushrod and equals about 0.37 mm. This value does not depend on differential system movement. Elasticity of this element allows for the pushrod's movement despite the constant angular position of the beam.

The movement of the pushrod, through the interactions with the rocker, causes one of the vehicle's wheel to be raised (or lowered). The amount by which the wheel is raised (lowered) is therefore dependent on the triangular beam's deformation value. This phenomenon allows for driving over a small terrain obstacle without causing a movement of the differential mechanism. This leads to an uneven distribution of the rover's mass on its wheels, which worsens the traction properties, so this effect is not desired.

The amount of bending of the triangular beam was correlated with the height of the vehicle's wheels using an MDS analysis. The relationship found is shown in Fig. 8. It was determined that bending of the triangular beam measured using FEM corresponds to the wheel raising to a height of 6.33 mm.

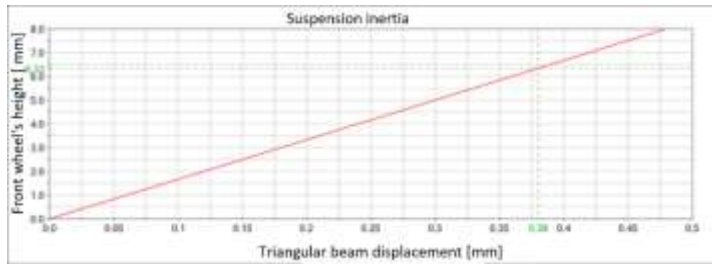

Fig. 8. Height of the front wheel depending on the triangular beam displacement

In the neutral position, which occurs during driving on a flat surface, the pushrod is positioned vertically. As a result of the suspension movement, the pushrod deviates from this position, leading to an increase in forces acting on this element. Pushrod's deviation from its neutral position is shown in Figure 9.

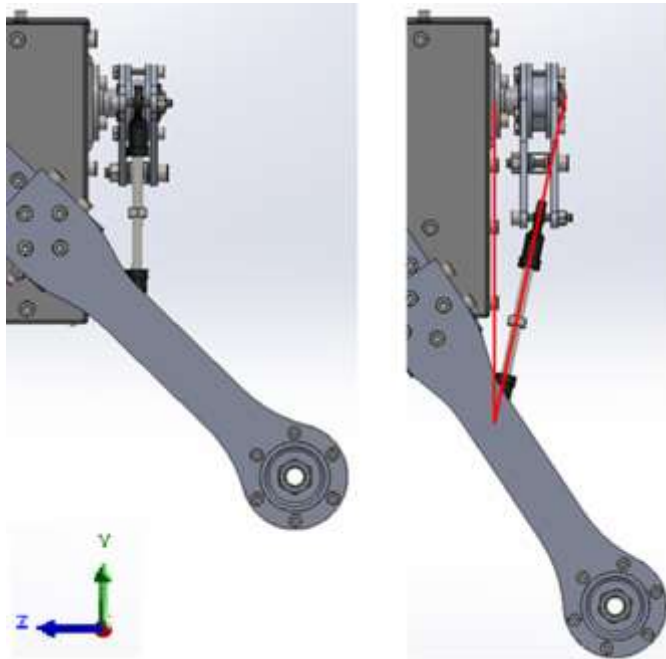

Fig. 9. Side view of the differential mechanism in different positions. On the left, the mechanism is in its neutral position. The pushrod is visible in a vertical position. On the right, the mechanism is shown while overcoming a terrain obstacle. The angle of inclination of the pushrod is shown in red.

The inclination of the pushrod resulting from a working suspension causes an increase in loads transferred through the mechanism in extreme positions (while climbing an obstacle with the maximum allowable height - for considered vehicle it is  $h = 300$  mm). During the design phase of this new differential beam system, significant pushrod deviations from a vertical plane were noticed. Plot of the pushrod's inclination depending on the vehicle's wheel rise is shown in the chart in Figure 10.

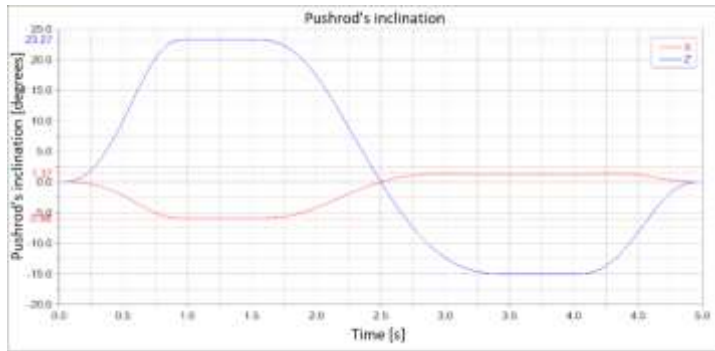

Fig. 10. Pushrod's inclination angle while overcoming uneven terrain with a height  $h = 300$  mm. Angular displacements relative to the X and Z axes (coordinate system shown in Figure 9)

The described phenomenon is unfavourable, however, its severity is mild as long as loads in the neutral position (when driving on a flat surface) are reasonable low. Compared to Scorpio X, where the pushrod's deviation was no larger than  $1.12^\circ$ , in the new generation of rovers, this value is as high as  $23.27^\circ$ . This makes a  $40.4$  N force acting on the triangular beam in the neutral position increase to a maximum of  $48.1$  N while driving over an obstacle. Although the relative increase in force is rather large, due to the small load in the neutral position, the element stress is still acceptable. In comparison to the previous generation of this vehicle, an improvement has been achieved. In Scorpio X - despite a much more favourable pushrod's inclination - the maximum value of a force is as high as  $207$  N.

## 5. INFLUENCE OF THE NEW MOUNTING ON THE AMOUNT OF SPACE TAKEN BY THE SUSPENSION SYSTEM

Due to the vertical orientation of the differential mechanism's plane of movement, there is no possibility for a collision with the rover's frame. The new mounting method allowed for a very unrestrained design of the system's kinematics. It was possible to formulate the critical dimensions so as to minimise forces and loads transmitted via the mechanism. This denotes a better optimisation of the individual elements composing the differential mechanism, i.e. reducing their mass or increasing



their rigidity, which is indirectly an outcome of changes in the orientation of the differential system to the vertical one.

In Scorpio X, massive bearings located in the middle of the frame's beam were used. In Scorpio 7 they were replaced by the two smaller bearing systems located closer to the ends of the beam.

The dimensions of a single bearing assembly are important due to the need to leave as much space inside the rover's body as possible for arranging the vehicle's onboard electronics. Using mounts with smaller sizes, even in larger quantities, makes it easier to lay out the internal components of a rover. The amount of space occupied by the suspension system outside a rover's body has also decreased. Total volume is now  $2.9 \text{ dm}^3$ , which is 24% of the space occupied by the same system in Scorpio X. The space occupied by the Scorpio 7 suspension in its full range of motion is marked in red on Figure 11.

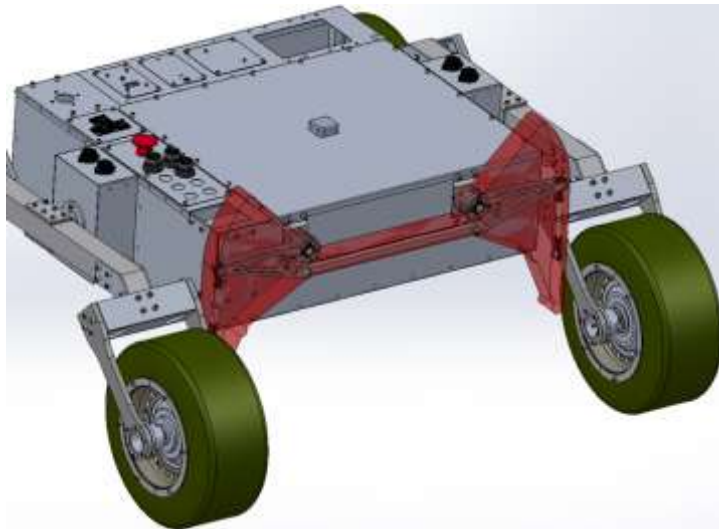

Fig. 11. Space required to allow movement of the suspension differential mechanism

## 6. ANALYSIS OF LOADS IN THE ROVER'S FRAME

Moving the mounting points of the differential system away from each other has a significant impact on the load carrying capability of the vehicle frame. Some of the rover's components are mounted to that frame, so it must be rigid to provide stable operating conditions for the vehicle. Displacements present in the frame decrease the suspension's rigidity, similarly as was the case for displacements in the differential mechanism. Changing the locations of the suspension's mounting points reduces the magnitude of displacement in the frame beam. The concept of a load distribution's influence on a deflection magnitude present in the beam is shown in Figure 12.

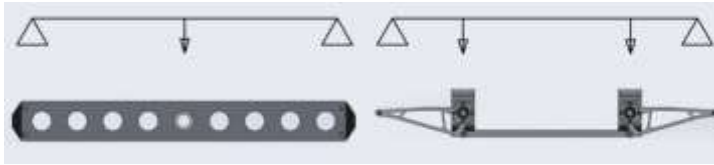

Fig. 12. Comparison of loads acting on the frame beams of Scorpio X (left) and Scorpio 7 (right) rovers. The distribution of loads in Scorpio 7 suspension leads to a smaller beam deflection value.

The frame was made out of square cross-section beams with dimensions of 20x20x1.5 mm and 15x15x1.5 mm. Additionally, in order to reduce weight, the frame's side panels were made as a cut-out lattice from a 3 mm thick sheet, whereas places intended to mount the rockers – from sheets with a thickness of 4 mm. These elements were made from 6060 aluminium due to the substantial strength-to-density ratio of this material.

In order to determine the magnitude of deflections in the frame's beams, FEM simulation was carried out in SolidWorks. Calculation parameters were determined based on the MDS analysis using MSC Adams software. Boundary conditions for the simulation are:

- Fixed displacement at the locations in which the frame attaches to the rockers;
- Triaxial stress acting on the differential mechanism's mounts. The applied forces are as follows: 500 N in the X axis, 30 N in the Y axis and 15 N in the Z axis.

A mesh built with the TETRA 10 elements, with a maximum edge length of 1 mm, was used. The results obtained are shown in Figure 13.

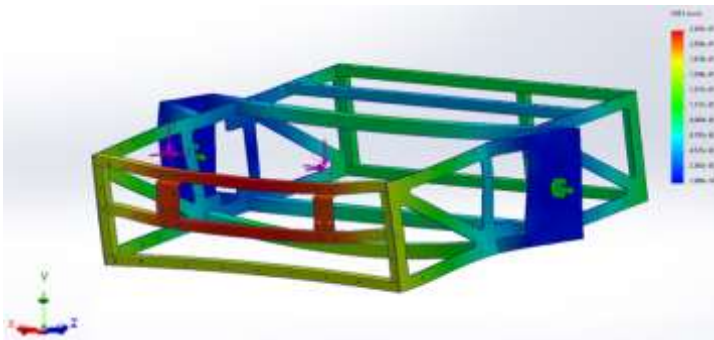

Fig. 13. Map of displacements of the loaded Scorpio 7 frame.

The maximum deflection was observed at the triangular beams attachment points, which was 0.22 mm. Compared to the Scorpio X frame, in which deflection reached 0.9 mm, a significant improvement was achieved. It is worth noting that due to the

construction of the new frame, displacement at the attachment points of the differential mechanism includes displacement resulting from twisting the frame at the rockers' attachment points. This effect is responsible for the apparent increase in measured value by about 0.15 mm. This phenomenon did not occur in the Scorpio X frame.

## 7. ROVER'S WEIGHT

The Scorpio 7 rover weighs 48 kg, which is more than its predecessor. This difference is largely due to increased frame dimensions and is not directly related to the suspension system.

The suspension system itself weighs 4.9 kg, which is 10.2% of the rover's gross weight, while the differential mechanism weighs 0.47 kg, which is 1.0% of the rover's weight. In Scorpio X, the suspension weighed 4.5 kg (10.0% of the rover's weight), and the differential mechanism weighed 0.53 kg (1.2% of the rover). The increased weight of the new vehicle's suspension is mainly caused by its enlarged dimensions (both the length and width of the frame have been extended), which requires the use of longer rockers. However, considering the weights of only the differential mechanisms, it can be inferred that the reduction in mass of this system through shape and dimensional optimisations had been achieved, despite increased track width.

## 8. COMPARISON OF THE SCORPIO X AND SCORPIO 7 SUSPENSION SYSTEMS' PARAMETERS

Evaluation of vehicle's improvements is only possible by comparing the values that describe both the old and new generations of the rover. The following table (Table 1) shows parameters describing the Scorpio X and Scorpio 7 suspension systems. All angular values are given for overcoming a terrain obstacle of height  $h = 300$  mm, which is the most demanding in terms of the stress experienced by the system. Despite the same requirements concerning maximum obstacle height for both rovers, the extended length of the Scorpio 7 rockers results in a decrease in their maximum angle of attack.

Tab. 1. List of parameters characterising the suspension systems of Scorpio X and Scorpio 7

Parameter	Scorpio X	Scorpio 7
Suspension system weight	4.5 kg	4.9 kg
Suspension system weight (excluding rockers)	530 g	470 g

Parameter	Scorpio X	Scorpio 7
Maximum frame deflection	0.9 mm	0.25 mm
Space occupied	12.1 dm <sup>3</sup>	2.9 dm <sup>3</sup>
Inclination of pushrods	1.2°	23.3°
Angle of attack of rockers	26.6°	20.8°

## 9. SUMMARY AND CONCLUSIONS

The modifications introduced have improved the parameters characterising the Scorpio 7 suspension system. A redesign of the differential mechanism reduced its weight while maintaining its full range of motion. The amount of space occupied both inside and outside the rover's body has decreased as well. Unfortunately, due to other changes not related to the suspension system, this weight abatement did not directly translate into a reduction in the overall weight of the vehicle. Compared to its predecessor, the new solution also features increased rigidity. In light of the above, the Authors consider the design of the Scorpio 7 rover a success.

## REFERENCES

- [1] KRZEMIŃSKI A., KOSOBUDZKI M., *Wstępna analiza wymagań stawianych kołom jezdnyom do pojazdu wysokiej mobilności*, Journal of Translogistics, 2020, Tom Vol. 6 (16), 1.
- [2] KRZEMIŃSKI A., KOSOBUDZKI M., *Projekt koła wykonanego w technologii przyrostowej do pojazdu wysokiej mobilności*, Journal of TransLogistics, t. 7, nr 1, Politechnika Wroclawska. Oficyna Wydawnicza Politechniki Wroclawskiej, 2021, s. 19—38
- [3] Regulamin zawodów Univeristy Rover Challenge  
<https://urc.marssociety.org/home/requirements-guidelines> (dostęp 26.10.2022 r.)
- [4] KOSOBUDZKI M., ŁAZIK P., *Adaptation of the ROS system to control the Scorpio autonomous vehicle*, [https://doi.org/10.37190/JoT2022\\_05](https://doi.org/10.37190/JoT2022_05)
- [5] Informacje prasowe na temat misji Mars 2020, Mars 2020 Perseverance Launch Press Kit, 2020, [https://www.jpl.nasa.gov/news/press\\_kits/mars\\_2020/download/mars\\_2020\\_launch\\_press\\_kit.pdf](https://www.jpl.nasa.gov/news/press_kits/mars_2020/download/mars_2020_launch_press_kit.pdf) (dostęp z dnia 1.12.2022 r.)
- [6] LOREK B., BERNAT R., KOSOBUDZKI M., *Analysis of the structure and operation of the Scorpio X rover suspension system*, [https://doi.org/10.37190/JoT2022\\_04](https://doi.org/10.37190/JoT2022_04)
- [7] SANDIN P. E., *Robot Mechanism and Mechanical Devices Illustrated*, 2003
- [8] RUSIŃSKI E., CZMOCHOWSKI J., SMOLNICKI T., *Zaawansowana metoda elementów skończonych w konstrukcjach nośnych*, Oficyna Wyd. PWr, Wrocław, 2000
- [9] MILLER S., *Teoria maszyn i mechanizmów. Analiza układów mechanicznych*, Oficyna wydawnicza PWr. Wrocław, 1996
- [10] MCCONVILLE J., *Introduction to Mechanical System Simulation Using Adams*, 2015

Corresponding author:

Bartłomiej Lorek, bartek.lorek2@gmail.com